

Preparation:

Read the mounting instructions carefully and make sure that all the parts are included as per the list. Turn off the engine and disconnect the battery when working on the electrical system. Remove the Barkbusters plastic guards from the bike. **Tools Required:** **3mm drill bit, 7mm drill bit and Phillips Head screwdriver.**

LED Light Installation:

VERY IMPORTANT: FOLLOW ALL INSTRUCTIONS CAREFULLY TO ENSURE A CORRECT FIT.

The LED Indicators can be mounted on the upper or lower face of the **VPS** and **STORM** plastic guards. The LED Indicators can be mounted on the upper face only of the **JET** plastic guards. This allows the LED indicators to be combined with the LED Running Lights. (LED Position Lights sold separately. Code: **LED-002**)

1. Enclosed is a paper Drilling Template to locate and drill the light mounting holes in the plastic guards. **IMPORTANT: CAREFULLY** cut out the appropriate template **perfectly** along the line.
2. Place the template on the REAR of the guard as per examples below and secure with clear tape. Using a scribe or centre punch apply pressure by hand to mark the centre of the three holes per template to be drilled. **Important:** When marking the drill holes place plastic guard on a cloth or soft surface to avoid damaging the front face.
3. Remove the template and drill through all holes with a **3mm** drill bit. Then enlarge all holes with a **7mm** drill bit. Remove any plastic burrs from around the holes.
Important: When drilling holes hold plastic guard in hand to avoid damaging front face, do not rest on a hard surface. Take care not to drill into your hand.



NOTE: Photos indicate correct placement of Drilling Templates on **REAR** of guard. Secure with clear tape prior to drilling.

4. Thread the LED wires (1) through the **MIDDLE** hole and fit the light in position. Position the backing plate (2) over the wires and ensure they exit at the cutout towards the inside of the guard.
5. Insert the screws (3) through the backing plate (2), and locate them in the screw holes of the LED light (1). Tighten screws (3) **being careful not to over tighten.**
6. Re-fit the plastic guard to the Barkbusters aluminium backbone.
7. Run the wires along the aluminium backbone to original motorcycle cabling and secure with supplied cable ties.

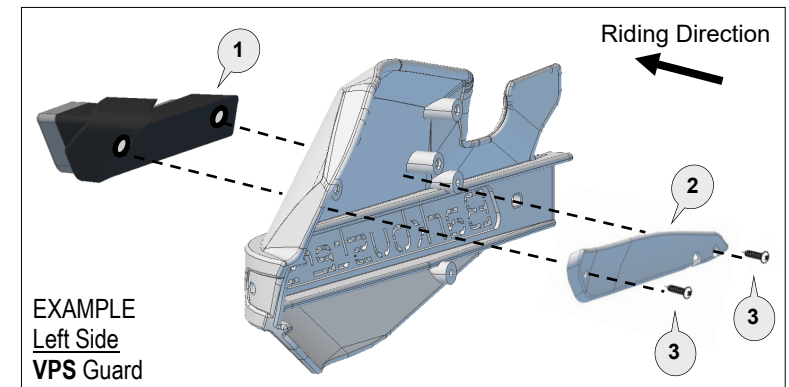

IMAGE: Left VPS guard with LED being mounted to upper face of guard.

Connecting to Electrical System:

12 Volt LED Indicators consume less power than original incandescent bulbs. If your motorcycle has original incandescent bulbs it may require an in-line Resistor (Code: **LED-RES-001**) for the LED indicators to flash correctly. Resistor usually not required on bikes with original LED indicators fitted.

1. If required, connect each resistor to the LED Indicator making sure the RED and BLACK wire connections match each other.
2. Un-plug original indicator wires and connect in the LED wires, ensuring the RED is connected to **Positive** and BLACK to **Negative**. If the connection plugs are not compatible with the motorcycle electrical connections, have them modified by a qualified technician to a compatible connection.
3. Power up motorcycle and check the indicator flash frequency is similar to the original setup. The correct flashing frequency is 90 (+/- 30) times per minute. If the flash frequency is not correct, have a service technician check the motorcycle's electrical system to determine if a different resistor is required.

ATTENTION:

Cover any bare wires or connections with electrical tape or heat shrink. Make a final check by operating the steering from lock to lock and check that all cables and wiring are not under tension or scrape or rest against any hot or moving parts. Ensure that all moving parts are not hindered in any way. After installation ensure that all previously removed parts are reinstalled correctly. Before riding perform a comprehensive check of all functions of the motorcycle. If any problems are detected do not ride the motorcycle until they have been rectified.

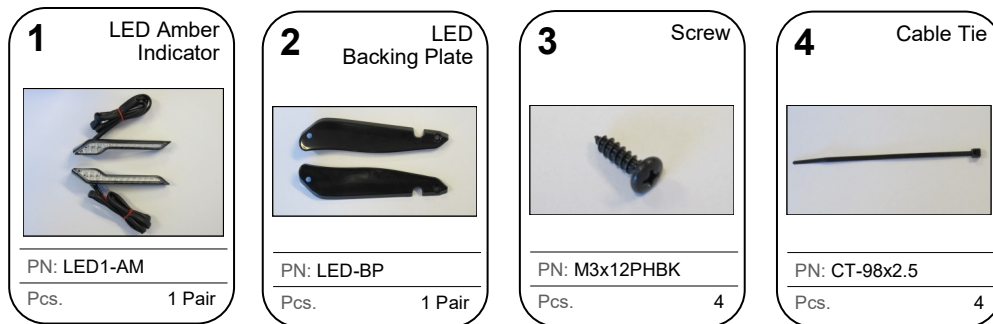

Phone: +61 (0)2 4271 8244
Email: info@barkbusters.net
Web: www.barkbusters.net



IMPORTANT:

Observe any laws and regulations specific to your state and country. Obtain appropriate authorisation where necessary. *The LED Indicator lights and Position lights are E mark approved.*

CAUTION:

Installation of the LED lights is safety-relevant work and can be complicated. We recommend the installation be performed by a motorcycle service technician. Rideworx accepts no liability for damages caused by improper mounting. Be careful not to over tighten the four 3mm fixing screws as they are secured into plastic. Carefully follow all the directions given in the mounting instructions. Non-conformance can lead to damage to the vehicle or risk to the rider. Before installing this product, check with your local regulatory authority to see if it complies with local vehicle standards. Check operation of all lights before use. Do not ride the motorcycle if any lights are not operating correctly. Check periodically that all screws are tight and lights are operating correctly.

Disclaimer:

A failure to follow these fitting instructions could cause serious injury, death or property damage. By installing and/or using this product you acknowledge that you accept these terms and have followed the fitting instructions.